



## **MDD**

### **THE MANUAL TRACTION / COMPRESSION STAND**



**MANUALLY OPERATED  
PRECISION STAND**

# THE MANUAL TRACTION / COMPRESSION STAND MDD

## MANUALLY OPERATED PRECISION STAND



### FUNCTION

The MDD stand is an easy-to-use, hand-operated precision stand for regularly moving a dynamometer or transducer connected to a readout console, when hand-holding is no longer sufficient.

Rotation of the crank at the top of the stand is the element ensuring regular tension and compression. The irreversibility of the worm screw within the crosshead ensures that the force on the part is maintained during the test.

The device is very popular for testing springs in conjunction with a digital ruler.

### TECHNICAL INFORMATION

<b>Activities</b>	Traction/Compression
<b>Capabilities</b>	1 000 N (200 lbf)
<b>Mountable sensors</b>	Dynamometer / Load cell
<b>Moving</b>	2 mm/tr
<b>Dimensions (Width*Height*Depth)</b>	240 x 630 x 230 mm
<b>Weight</b>	6 kg
<b>Stroke</b>	400 mm
<b>Sensor mounting</b>	Dovetail

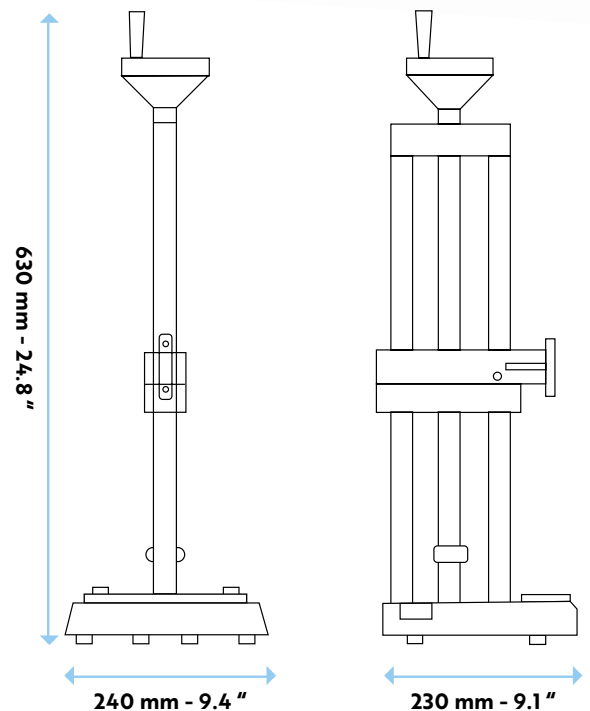
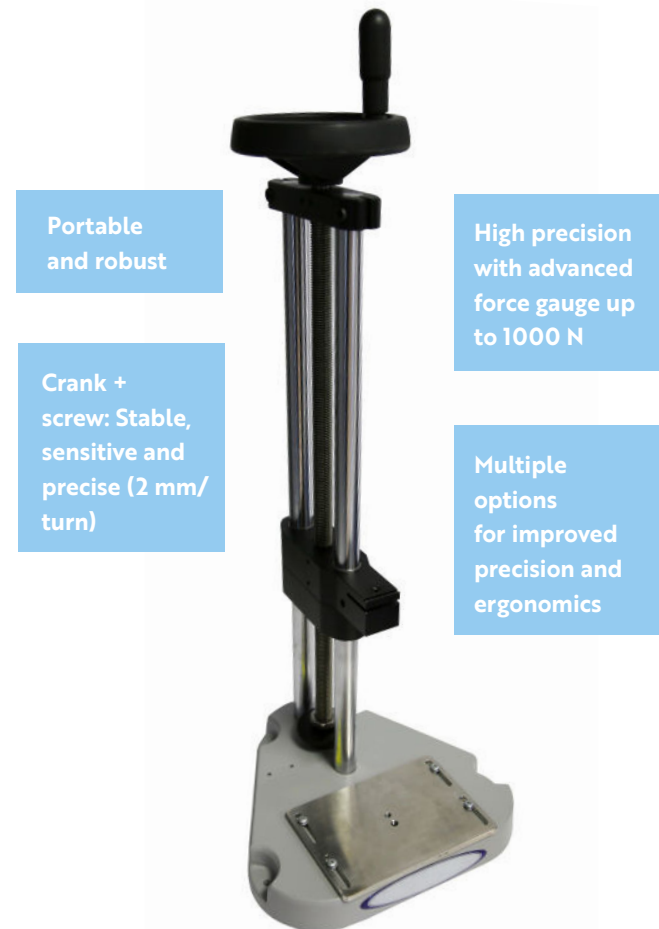

## OPTIONS

Kit of two feet for horizontal position (1)
475 mm digital optical ruler (resolution 0.01 mm) (2)
2 16 mm and 38 mm dovetail expansions (3) for easy dynamometer replacement



## EASIBLE TESTS

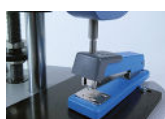

## ACRN A GLOBAL OFFER for your packaging quality controls

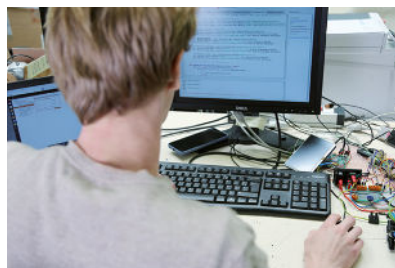
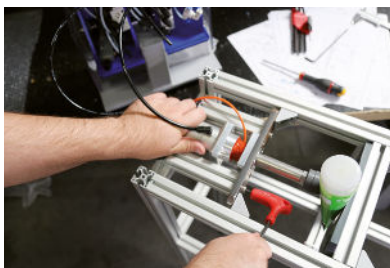

### Calibration and annual maintenance

ACRN is equipped with a metrology laboratory.

### Setting up tests, choice of materials, state of the art, work on repeatability

we can advise you according to your needs (technology, budget, ergonomics).

### Leak testing and dynamometric testing

Our skills and equipments for leak testing and dynamometric testing for packaging

*Major manufacturers have trusted us for many years*



**ACRN** - Parc d'activités du Moulin d'Ecalles - 76750 BUCHY - France

Tél. : +33 (0)2 32 80 81 40 - Fax : +33 (0)2 32 80 14 44 - [www.acrn.fr](http://www.acrn.fr) - [commercial@acrn.fr](mailto:commercial@acrn.fr)